

## Vertical Sealless Sprayer/Washer Pumps

- **Cast Iron Construction with 300 Series Investment Cast Stainless Steel Impeller**
- **Stainless Steel Pump Shaft**
- **No Bottom Bearing!**
- **Dual Volute Design Reduces Radial Load on Motor**
- **Maximum Temperature 200° F**
- **Maximum Flow 140 GPM**
- **Maximum Head 140 Ft. (61 PSI)**
- **Stainless Steel Suction Screen**
- **Includes Heavy Duty Universal Mounting Plates**
- **3 HP to 7-1/2 HP Totally Enclosed Fan Cooled (TEFC) Motor**
- **Standard 56C or JM Shaft Motors**



Model 5571-95

AMT Vertical Sealless Sprayer/Washer pumps are designed for OEM, automotive and industrial washing machines, parts cleaners, spray booths and cooling towers. "No bottom bearing" design and stainless steel impeller resists erosion from abrasives and ensures a long, maintenance free life for the pump. CNC machined stainless steel pump shafts. Built-in stainless steel suction screen protects pump from clogging and damage caused by large solids. Heavy duty universal mounting plates permit easy installation into existing tanks, booths, equipment, etc.

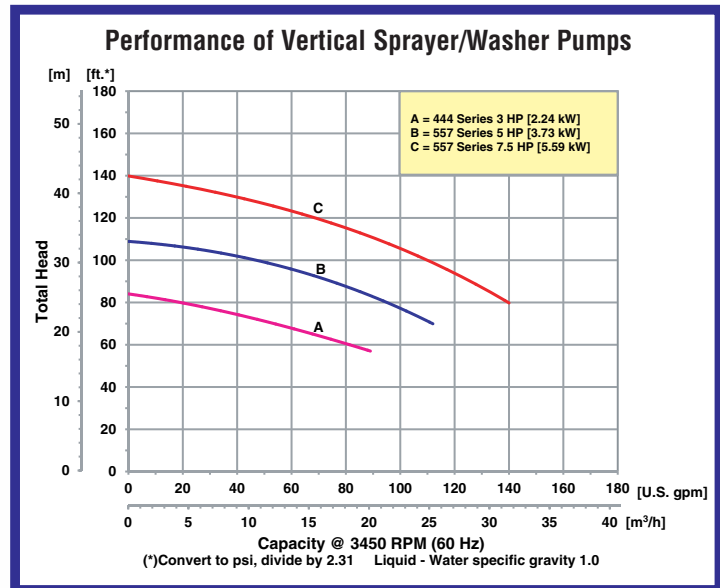

400 Spring Street • Royersford, PA 19468 USA

[www.amtpump.com](http://www.amtpump.com) • 888-amt-pump (268-7867)

For use with nonflammable liquids compatible with pump component materials.

CLT-7



# Vertical Sealless Sprayer/Washer Pumps

## Pump Dimensional & Specification Data

Model	Curve	HP	PH	ENC	Voltage @ 60 Hz+	Full Load Amps	DIS*	A	B	C	D	E	L	W	H**	Ship Wt. (Lbs.)
4445-95	A	3	1	TEFC	230	14	1½	6.5 [165.1]	15.0 [381.0]	3.5 [88.9]	13.5 [342.9]	17.0 [431.8]	9.5 [241.3]	10.8 [274.3]	29.7 [754.3]	78
4446-95		3	3	TEFC	230/460	8/4										73
5572-95	B	5	3	TEFC	208-230/460	14/7	1½	8.4 [213.3]	17.0 [431.8]	4.0 [101.6]	14.0 [355.6]	17.8 [452.1]	12.0 [304.8]	15.0 [381.0]	32.0 [812.8]	130
5571-95	C	7½	3	TEFC	208-230/460	18/9										150

(\*) Standard NPT (Female) pipe thread.

(\*\*) This dimension may vary due to motor manufacturer's specifications.

(+) 3-Phase models can also operate on 50 Hz. (This will change full load amps, service factor and RPM.)

NOTE: Dimensions are in inches (millimeters) and have a tolerance of ± 1/8".

NOTE: Electric supply for ALL motors must be within ±10% of nameplate voltage rating (e.g. 230V ±10%= 207 to 253).

Models: 4445-95 & 4446-95

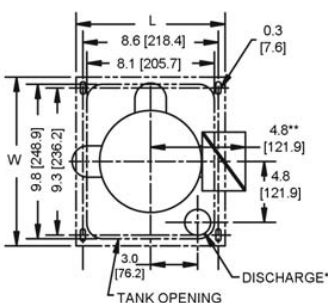

Models: 5571-95 & 5572-95

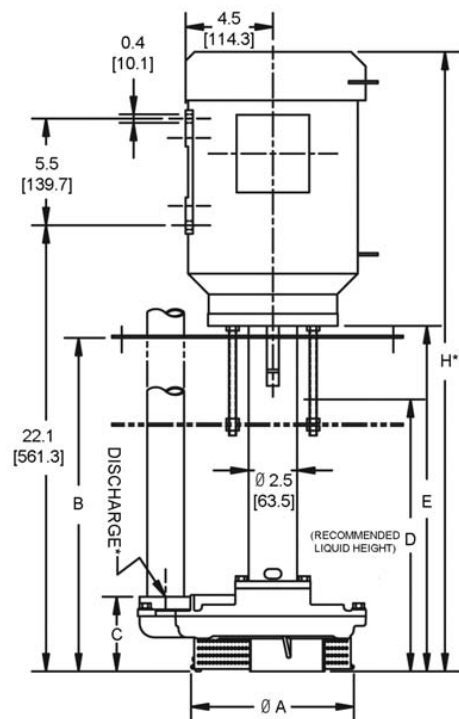
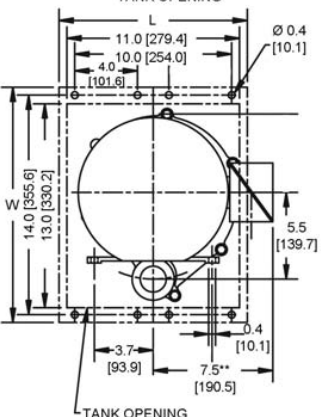

## Standard Features

- Cast Iron Construction with 300 Series Investment Cast Stainless Steel Impeller
- Stainless Steel Pump Shaft
- **No Bottom Bearing!**
- Maximum Temperature 200° F
- Maximum Flow 140 GPM
- Maximum Head 140 ft. (61 PSI)
- Stainless Steel Suction Screen
- Includes Heavy Duty Universal Mounting Plates
- Standard 56C or JM Shaft Motors

### Maximum Recommended Viscosity: 100 SSU

Hazardous Duty/Explosion Proof motors available from stock ranging from 1 to 10 HP (applies to 557 Series only); CALL FOR QUOTATION & LEAD TIME!

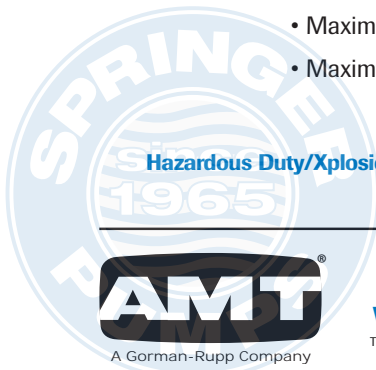

Manufacturer of AMT & IPT Pumps

400 Spring Street • Royersford, PA 19468 USA

[www.amtpump.com](http://www.amtpump.com) • 888-amt-pump (268-7867)

The Gorman-Rupp Company reserves the right to discontinue any model or change specifications at any time without incurring any obligation. ©2012 American Machine and Tool Company. All rights reserved.



CLT-8

Tel: 866-777-6060  
Fax: 866-777-6383

Springer Pumps, LLC

[www.springerpumps.com](http://www.springerpumps.com)  
Int'l: +1 267-404-2910